

**Please, read this manual  
carefully before use!**

**Owner's Manual**



## **Gasoline lawn mower**

**KS 46LMG  
KS 51LMG-SP**

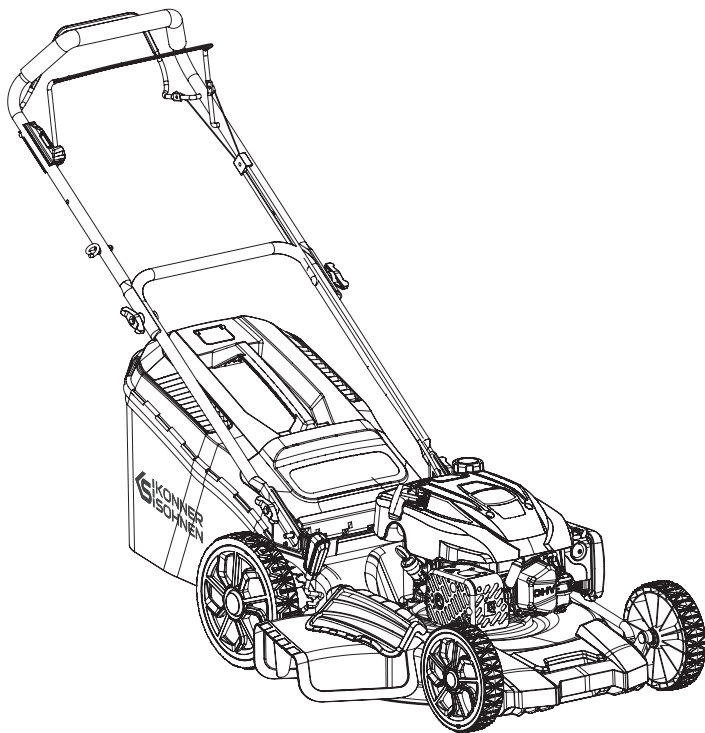



Thank you for choosing **Könnner & Söhnen®** products. This manual provides a brief description of safety requirements, setup procedures, and operating instructions. More information is available in the support section at: [konner-sohnen.com/pages/instructions](http://konner-sohnen.com/pages/instructions)

You can also download the manual by scanning the QR code or by visiting the official importer's website at [www.konner-sohnen.com](http://www.konner-sohnen.com)



*Please, read this manual  
carefully before use!*

The manufacturer reserves the right to make changes that may not be reflected in this manual, including:

- The manufacturer reserves the right to make changes in the product design, configuration and construction.
- The images and drawings in this manual are for reference only and may differ from the actual components and inscriptions on the products.

Contact information that you are free to use in case of any problems can be found at the end of this manual. All information in this manual is correct to the best of our knowledge at the time of publication. The current list of service centers can be found on the official importer's website at [www.konner-sohnen.com](http://www.konner-sohnen.com)



**ATTENTION – DANGER!**



**Failure to follow the recommendations marked with this sign may lead to serious injury or death of the operator or third parties.**



**IMPORTANT!**



**Useful information while operating the machine.**

## IMPORTANT SAFETY INFORMATION

1



**WARNING!**



**Read all instructions. Failure to follow the safety guidelines listed below may result in electric shock, fire and/or serious injury.**





1. Read instructions carefully, become familiar with controls and proper use of equipment.
2. Lawn mowers can only be used for mowing grass, mulching grass, collecting fallen leaves, please do not use them for any other purposes.
3. When cutting, be sure to wear boots and long pants, and do not start the product when you are bare-foot or wearing sandals.
4. Wearing earplugs or limiting the running time can reduce the harm caused by noise.
5. Check the lawn mower and related parts before use:
  - Check for oil or gasoline leakage around and under the engine.
  - Check the blade, blade fastening bolt for wear or damage. Do not use the tool when it is broken, cracked, bent, or loose bolt.
  - Check whether the muffler guard is installed correctly and not damaged.
  - Check that the installed baffle or shield and safety devices (guide plate or grass bag, etc.) are in place, and the installation is firm and undamaged
  - Check that all nuts, bolts, and screws are complete and tightened so that the equipment is in a safe working condition.
6. Objects which can be picked up by the blade and thrown is a potential hazard to you and others. Look for things like stones, sticks, bones, and wire. Remove them from the mowing area.

7. Stop the cutting device(s) if the machine has to be tilted for transportation when crossing surfaces other than grass, and when transporting the machine to and from the area to be mowed.
8. During operation, the lawn mower and flying objects can be dangerous and cause serious injury and property damage. Do not allow unauthorized persons, children, or animals to approach the working area. Maintain a safe distance from objects. Never leave the lawn mower unattended. Do not allow children to play with the lawn mower.
9. Mow only in daylight or good artificial light.
10. Do not operate the lawn mower while being tired, ill or under influence of alcohol or drugs.
11. Avoid operating the equipment in wet grass, where feasible.
12. Avoid operating in rainy days.
13. Mowing on slopes:
  - Always be sure of your footing on slopes.
  - Mow across slopes, never up and down.
  - Walk, and never run.
  - Do not mow on excessively steep slopes.
14. Gasoline is highly flammable:
  - Store fuel in containers specifically designed for this purpose.
  - Stay away from fire and do not smoke while refueling.
  - Refuel outdoors only.
  - Add enough fuel and check oil before starting the engine.
  - Never remove the cap of the fuel tank or add gasoline while the engine is running or when the engine is hot.
  - Before handling fuel, switch off the engine and let it cool.
  - If gasoline is spilled, do not attempt to start the engine but move the machine away from the area of spillage and avoid creating any source of ignition until the gasoline vapors have dissipated.;
  - Install the fuel filler cap securely.
  - Keep away from source of heat, spark and naked fire. Eg.: lamp in service, gridiron, electric appliance, electric tools and vehicles.
15. Driving lever shall be released when starting the engine.
16. Keep feet away from blades when starting.
17. Avoid mower inclination when starting.
18. Do not adjust the cutting height while the engine is running.
19. Do not change engine RPM original factory setting or keep engine running overspeed.
20. Do not stand in front of grass discharging area when starting.
21. Stop the engine when there's any abnormal noise or vibration:
  - Check if there's damage.
  - Replace or repair any damaged parts
  - Check and tighten any loosen parts.
22. Be cautious when reversing or pulling back the mower.
23. When clearing jammed material or cleaning the lawnmower, stop the engine and wait that the cutting blade had come to a complete stop.
24. Do not keep hands or feet near or under the rotating parts. Keep clean of the grass discharging area.
25. Do not start or run the engine in a closed area. Run the engine at ventilated area to avoid CO accumulation harm to human.
26. Do not add too much fuel. Avoid spilling.
27. Do not touch the muffler before the engine has cooled.
28. Stop the engine and disconnect spark plug cap in below cases:
  - Before cleaning obstacles and clog.
  - Before inspecting, cleaning and maintaining the mower.

- Check the damage of mower after clashing with objects. Restart the engine after repairing.
  - Stop the engine and repair whenever there's any abnormal vibration.
29. Stop the engine in the following cases:
    - Whenever you need to leave the mower.
    - Before refueling the mower or adding oil.
    - When passing through a gravel driveway, sidewalk, or road
    - When the mower is being transported, especially on slopes or uneven surfaces.
  30. Do not store the mower in any location where sparks, open flames, or hot surfaces are present, especially when there is fuel in the tank.
  31. Allow the engine to cool before storing the mower in a closed area.
  32. To reduce the fire hazard, keep the engine, muffler, battery compartment (if applicable) and gasoline storage area free of grass, leaves or excessive grease.
  33. Do not use the mower:
    - If the operator has not fully read or understood the manual, or lacks basic operating skills.
    - When the operator is fatigued, ill, under the influence of alcohol, medication, or other substances that impair alertness.
    - If the operator is a minor, elderly, or physically impaired.
    - If the operator is not wearing appropriate protective equipment.
    - If no protective device (shield) is installed or if the protective device is damaged.
    - If the machine has not been inspected, or if any parts are loose, damaged, or missing.
    - If people, especially children or pets, are nearby.
  34. If the mower is used improperly or poorly maintained, it may become hazardous.
  35. The company shall not be liable for any machine damage or personal injury caused by unauthorized modification.
  36. Do not dismantle the mower yourself. In case of malfunction or required repairs, consult your authorized dealer.

**SYMBOLS** 2

The rating plate on your tool may show symbols. These represent important information about the product or instructions on its use.

	Read all safety warnings and all instructions. Failure to follow the warnings and instructions may result in electric shock, fire and/or serious injury.
	Denotes risk of personal injury, loss of life, or damage to the tool in case of non-observance.
	Wear personal protective equipment.
	Ensure the engine is filled with the correct amount of oil before starting.

	Hot exhaust can burn you. Stay away from the exhaust area while the engine is running or immediately after use.
	Keep hands and feet away from the rotating blades. They can cause severe cuts.
	Sound power level L <sub>WA</sub> indicated in dB.
	Beware of objects being thrown by the mower. Keep a safe distance and keep other people away.
	Do not clean the mowing area while the lawn mower is running
	Keep children at least 10 m away from the work area.
	Ensure that the components are securely fastened before using the machine.
	Do not operate the lawnmower on excessively steep slopes.
	Before and during maintenance, the engine should be turned off and the spark plug cap should be removed.
	Do not touch. Hot surfaces can cause burns.
	Do not use or store the machine outdoors in rainy conditions.

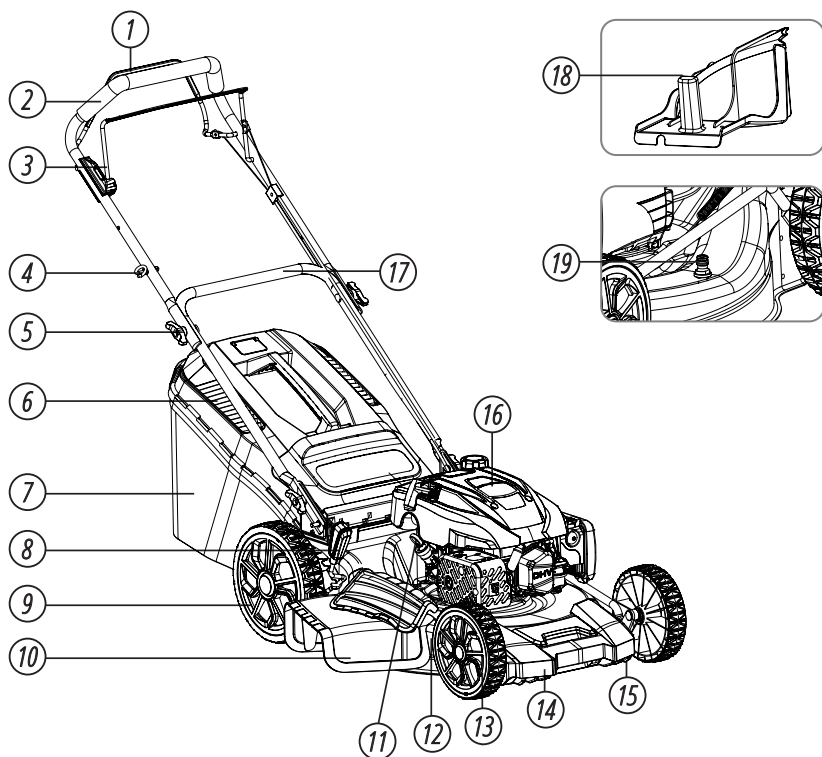

- |  |                            |                        |
|--|----------------------------|------------------------|
| 1. Drive control lever (for model KS 51LMG-SP) | 7. Grass bag               | 14. Front deck housing |
| 2. Foam grip                                   | 8. Height adjustment lever | 15. Grass comb         |
| 3. Brake lever                                 | 9. Rear wheel              | 16. Engine             |
| 4. Cable clip                                  | 10. Side discharge chute   | 17. Lower handle bar   |
| 5. Handle lock                                 | 11. Oil dipstick           | 18. Mulching plug      |
| 6. Grass bag frame                             | 12. Deck                   | 19. Wash-out port      |
|  | 13. Front wheel            |                        |



**IMPORTANT!**



**Manufacturer reserves the right to make changes and/or improvements in design, components set and technical attributes without notice and without incurring obligation. The pictures in this manual are schematical and may not match the parameters of original product.**

### PACKING LIST

- |                                |                               |
|--------------------------------|-------------------------------|
| 1. Lawn mower – 1 pc           | 7. Locking knob – 4 pcs       |
| 2. Grass bag – 1 pc            | 8. M8 nut × 35 – 2 pcs        |
| 3. Side discharge chute – 1 pc | 9. Wire clip – 1 pc           |
| 4. Mulching plug – 1 pc        | 10. Square neck bolts – 2 pcs |
| 5. Upper handlebar – 1 pc      | 11. Tapping screw – 2 pcs     |
| 6. Lower handlebar – 1 pc      | 12. Manual – 1 pc             |

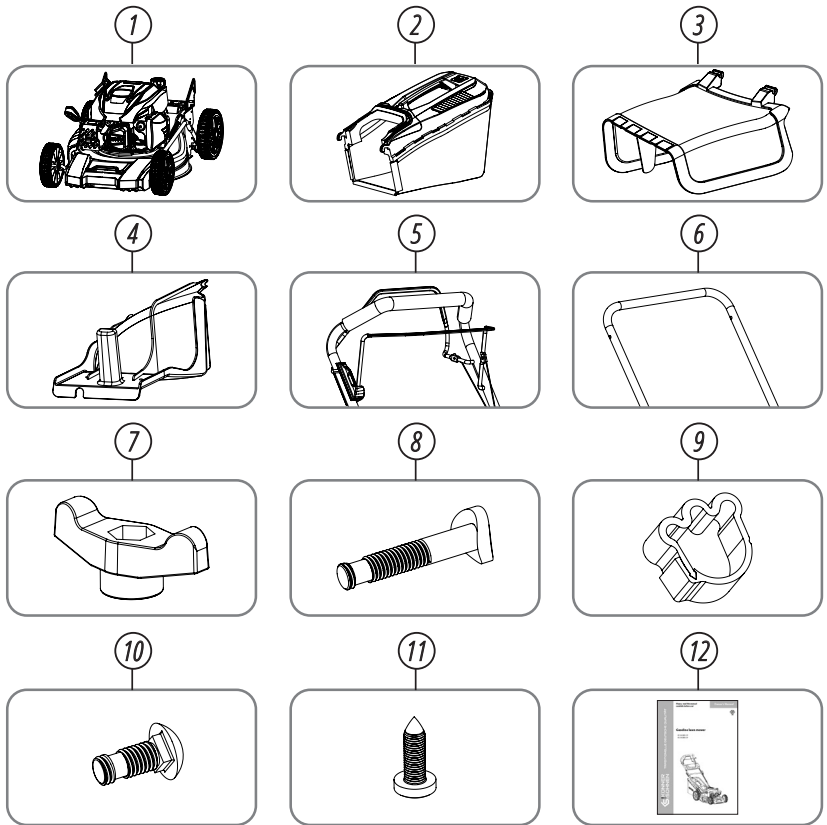

## DESIGN, EXTERIOR APPEARANCE OF THE ENGINE

1. Starter cord handle
2. Dipstick/Oil fill tube
3. Muffler
4. Spark plug
5. Primer
6. Air filter housing
7. Fuel tank and cap
8. Connection battery cable, positive (if applicable)
9. Connection battery cable, negative (if applicable)
10. Start switch connection
11. Relay (if applicable)
12. Electric starter motor (if applicable)
13. Brake assembly
14. Choke mechanism
15. Engine switch (if applicable)

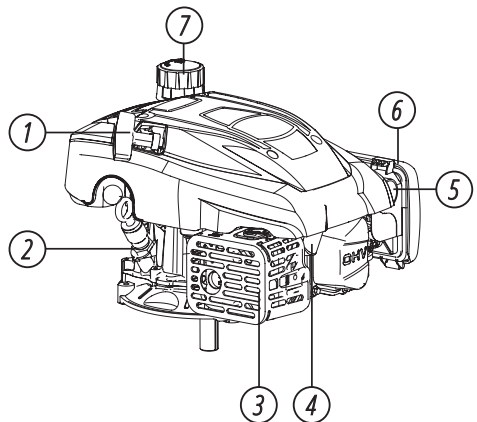

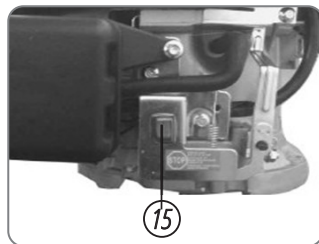
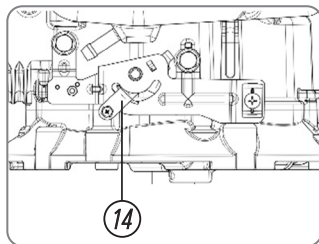
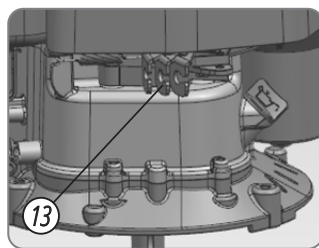
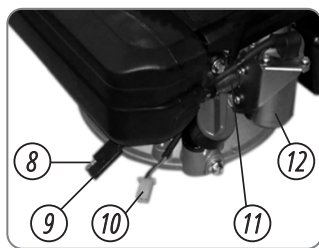

## SPECIFICATIONS

4

Model	KS 46LMG	KS 51LMG-SP
<b>MOTOR CHARACTERISTICS*</b>		
<b>Max power</b>	2.9 kW / 4.0 hp	3.2 kW / 4.5 hp
<b>Motor type</b>	gasoline powered one-cylinder, four-stroke air-cooled	
<b>Engine model</b>	RV145-S	RV170-S
<b>Engine cylinder volume</b>	144 cm <sup>3</sup>	170 cm <sup>3</sup>
<b>Cylinder</b>	cast-iron sleeve	cast-iron sleeve
<b>Fuel tank volume</b>	0.8 l	0.8 l
<b>Crank case volume</b>	0.5 l	0.5 l
<b>Engine start</b>	recoil	recoil
<b>LAWN MOWER CHARACTERISTICS</b>		
<b>Cutting width</b>	460 mm	510 mm
<b>Adjustable height position</b>	25-75 mm, 7 positions	25-75 mm, 7 positions
<b>Driving system</b>	Push	self-propelled
<b>Driving speed</b>	–	3.4 km/h
<b>Collection bag</b>	60 l	60 l
<b>Noise level</b>	94 dB	96 dB
<b>Function</b>	6 in1: rear collection, side discharge, mulching, cleaning port, rear discharge, leaf collection	7 in1: rear collection, side discharge, mulching, cleaning port, self propelled, rear discharge, leaf collection
<b>Wheels diameter</b>	front 178 mm, rear 203 mm	front 203 mm, rear 252 mm
<b>Working temperature</b>	from 5 °C to 40 °C	from 5 °C to 40 °C
<b>Gross dimensions (L×W×H)</b>	785×565×440 mm	855×575×440 mm
<b>Gross weight</b>	27 kg	30 kg

\*Engine power will decrease 3.5% for each 1,000 feet (300 meters) above sea level and 1% for each 5.6 °C above 25 °C. The engine will operate satisfactorily at an angle 10°. Refer to the equipment operator's manual for safe allowable operating limits on slopes.

We recommend that you see and our Authorized Dealer for all maintenance and service of the engine and engine parts. Use only genuine our parts.

## ASSEMBLY INSTRUCTIONS

# 5

### UNPACKING INSTRUCTIONS

- Installation must be completed before using the mower.
- Unpack the parts and check them against the packing list.
- Check the parts carefully. Ensure there's no damage during transportation.
- If any parts are missing or damaged, do not use the product and contact your dealer.

### HANDLEBAR INSTALLATION

1. Remove the lower handlebar. Insert the insulating plate into the left and right handlebar slots. Align them all and fasten them with two M8×35 carriage bolts and secure using the triangle locking knobs (Fig. 1). (Note: For the manual push model, replace M8×35 bolts with M8×26 bolts. Do not use the insulating plate).

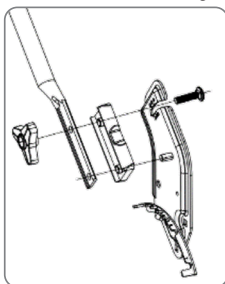

Fig. 1

2. Mount the upper handlebar onto lower handlebar. Thread the quick-lock bolt through the flat Ø8 washer, then connect the upper and lower handlebars together and tighten them to a certain degree with an M8 nut (Fig. 2).

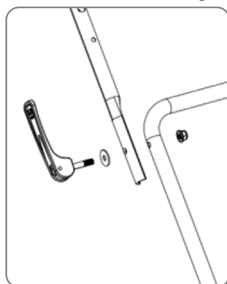

Fig. 2

### SIDE DISCHARGE OUTLET INSTALLATION

Pull up the side discharge lock. Lift the side discharge cover (Fig. 3) and hang upside down the side discharge outlet onto the spindle. Put down the side discharge cover and press well the side discharge outlet (Fig. 4).

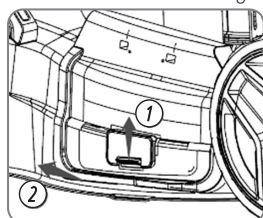

Fig. 3

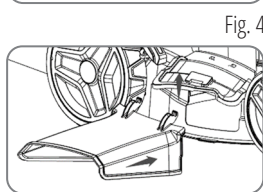
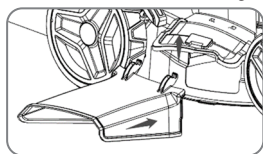

Fig. 4

### GRASS BAG INSTALLATION AND REMOVAL (Fig. 5)

#### Installation (only when engine is off)

1. Raise the discharge guard, and hook the grass bag frame onto the housing as shown.
2. Release the discharge guard to secure the grass bag in place.



#### Removal (Only when engine is off)

1. Raise the discharge guard, grasp the grass bag handle and remove the grass bag.
2. Release the discharge guard.
3. When the grass bag is clear of the discharge guard, you can lift the grass bag through the handlebars, or remove it from the rear of the mower below the handlebar.



Fig. 5



**WARNING!**



**Do not operate the mower when the grass bag is being installed or removed. Ensure that the grass bag hoop is securely fixed and that the back cover fits properly over the grass bag.**



**WARNING!**



**During normal use, the grass bag may wear out. To reduce the risk of injury, check the grass bag frequently and replace it if it is worn or damaged.**

Fig. 6

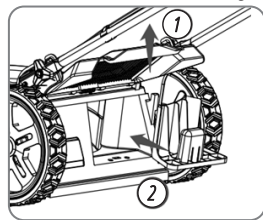

### MULCHING PLUG INSTALLATION (Fig. 6)

(When engine is off)

1. Lift the rear cover; install the mulching plug onto rear discharge outlet and lock.
2. Put down rear discharge cover.
3. Fasten the cord to the handle with a cable clamp (Fig. 3).

### ASSEMBLE THE GRASS CATCHER

1. Clip the grass bag over the metal frame (Fig. 4). Make sure to be secured.
2. Lift the rear discharge cover and hook the grass catcher.
3. Release the rear discharge cover and secure the grass catcher in position (Fig. 5).

### ASSEMBLY THE MULCHING KIT

1. Remove the grass bag (Fig. 6).
2. Insert the mulch kit into the opening.
3. Close the flap.

## PRE-OPERATION CHECKS

6

### CHECK PROTECTIVE DEVICES

Be sure to wear protective clothing. Long pants and eye protection can lower your risk of injury from thrown objects. Wear footwear that protects your feet and won't let you slip if you mow on slopes or uneven ground.

### CHECK YOUR LAWN

For your safety and for the safety of others, always inspect the area before mowing.

Anything which can be picked up by the blade and thrown is a potential hazard to you and others. Look for things like stones, sticks, bones, and wire. Remove them from the mowing area.

Check the length and condition of the grass, so you will know what cutting height and mowing speed to use. Avoid mowing wet grass. Not only will wet grass clog your deck and collect in clumps on the lawn, it also gives poor traction, increasing your risk of losing your footing.

### CHECK PEOPLE AND PETS

People and animals near the mowing area can move into your path or into a position where they could be struck by thrown objects. Clear the area of people and pets, especially children. Their safety is your responsibility.

### CHECK THE LAWN MOWER

#### Oil level:

Check the engine oil level with the engine stopped and the mower on a level surface.

1. Remove the oil filter cap/dipstick and wipe it clean.
2. When oil level is below lower limit, add the recommended oil to the upper limit level.
3. Secure the oil dipstick.



**WARNING!**



**Running the mower with low oil will cause engine damage and will not be covered under the warranty.**

#### Fuel level:

Refuel in a well-ventilated area before starting the engine. If the engine has been running, allow it to cool. Remove the fuel filler cap and check the fuel level. Refill the tank if the fuel level is low. Fill the tank to

approximately 1.5 inches (38 mm) below top of neck to allow for fuel expansion. Refuel carefully to avoid spilling fuel. If fuel spill, wait until it evaporates before starting engine. Do not overfill; There should be no fuel over the upper limit mark. After refueling, tighten the fuel filler cap securely.



NOTE



**Fuel can damage paint and plastic. Be careful not to spill fuel when filling your fuel tank. Damage caused by spilled fuel is not covered under warranty.**

#### Fuel recommendations:

**Use only unleaded gasoline with an octane rating of 90–95 containing no more than 10% ethanol.** This engine is certified to operate on unleaded gasoline. Unleaded gasoline produces fewer engine and spark plug deposits and extends exhaust system life. Never use stale or contaminated gasoline or an oil/gasoline mixture. Avoid getting dirt or water in the fuel tank. Occasionally you may hear light “spark knock” or “pinging” (metallic rapping noise) while operating under heavy loads. This is no cause for concern. If spark knock or pinging occurs at a steady engine speed, under normal load, change brands of gasoline. If spark knock or pinging persists, see your servicing dealer.



NOTE



**Running the engine with persistent spark knock or pinging can cause engine damage. Running the engine with persistent spark knock or pinging is misuse, and the Warranty does not cover parts damaged by misuse.**



WARNING!



**Gasoline is highly flammable and explosive. Stay away from smoke, spark and naked fire when handling fuel.**

#### Air cleaner:

Make sure the air filters are clean and in good condition. A dirty air filter will restrict air flow to the carburetor, reducing engine performance.

Remove the air cleaner cover and check if air filter is damaged or dirty.

- Replace when it's damaged; Clean with kerosene and dry it when it's dirty.
- Prohibit running lawn mower without air cleaner



WARNING!



**Running lawn mower without air cleaner will damage lawn mower and not covered under the warranty.**

#### Blade:

Before each use, check the cutter blade for damage or excessive wear (Fig. 7).

- Check if blade is with any split, bending or excessive wear. Replace when it's necessary.
- Check if the blade is loose. Secure it with torque 40N·m.

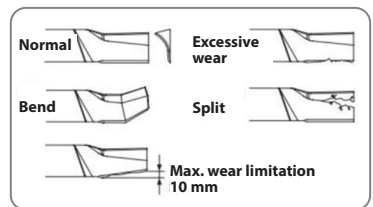

WARNING!



- **To avoid severe personal injury when inspecting or servicing the blade, disconnect the spark plug cap to prevent accidental starting, and wear heavy gloves to protect your hands from the cutter blade.**
- **Never operate the mower with a worn, damaged, split or dented blade. Pieces of blade which breaks off and is thrown outwards can cause serious bodily injuries.**
- **Blade wear is increased when the mower is used on sandy soils. Check the blade more often when the mower is used in these conditions.**

**WARNING!**

- A dull blade can be sharpened, but a blade that is worn out, bent, cracked, or otherwise damaged must be replaced. A worn or damaged blade can break, causing blade pieces to be thrown from the mower.
- When a blade needs sharpening or replacement, take the lawn mower to your servicing dealer, or, if you have a torque wrench and other proper tools, you can remove and install the blade yourself.

**NOTE**

**Start the machine to observe the blade. If any abnormal vibration, stop using it immediately, check it in time, and send it to the service center if necessary.**

### Rear cover, side cover (optional)

Check whether the rear cover and side discharge cover are cracked or damaged, and replace if necessary.

**WARNING!**

**It is forbidden to run the lawn mower without rear cover and side cover, otherwise it may cause personal injury.**

### Grass bag

A lawn mower works like a vacuum cleaner; it blows air through the bag, which traps the grass clippings. Always empty the grass bag before it becomes filled to the limit of its capacity. Bagging performance will diminish after the bag becomes about 90% filled. Also the bag is easier to empty when not packed full.

### Inspection

Inspect the grass bag before use. Check for holes, tears, and excessive wear.

The grass bag will wear during normal use and will eventually require replacement.

### Fasteners

Check whether all fasteners (bolts, nuts) are complete and loose, replace and tighten them if necessary.

### Cutting height

Check the deck cutting height settings.

To adjust cutting height, pull the adjustment lever toward the wheel, and move it into another notch.

If you are not sure what cutting height to select, start with a high setting and check the appearance of the lawn after mowing a small area. Then readjust cutting height if necessary.

**WARNING!**

**Stop the engine when adjusting the cutting height!**

**OPERATING****7**

### Precautions:

- Before operating the moer for the first time, please review the SAFETY INSTRUCTIONS and SAFE MOWING PRICTICES.
- Even if you have operated other mowers, take time to become familiar with how this mower works and practice in a safe area until you build up your skills.
- For your safety, avoid starting or operating the engine in an enclosed area such as a garage.

**ATTENTION – DANGER!**

**Your mower's exhaust contains poisonous carbon monoxide gas which can collect rapidly in an enclosed area and cause illness or death.**

## USE OF THE CONTROL DEVICES DURING CUTTING

Fig. 8

### Brake lever

Brake lever connects flywheel brakes with ignition switch. Pull back the brake lever against the handle before starting the engine (Fig. 9). Release the brake lever to stop the engine (Fig. 8). If keeping the brake lever released, the starter rope will not be pulled out due to flywheel brake.

Holding the brake lever and handlebar continuously will keep the engine and blade rotating. To release the brake lever, engine will stop running and blades will stop rotating.

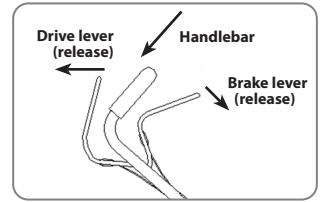

**WARNING!**



**When you need to leave halfway, you should release the brake lever to stop the engine**

### Driving lever (optional)

Fig. 9

The driving lever controls the clutch of gears inside gear box through lever ropes to disengage and engage in order to drive / stop the rear wheels walking.

Press the driving lever, lawn mower will walk forward (Fig. 9). Release the driving lever, lawn mower will stop walking (Fig. 8).

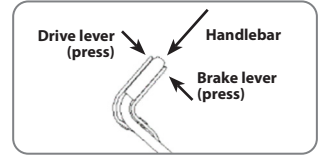

**WARNING!**



- **Release the driving lever before starting the engine. If holding the driving lever, the lawn mower will move forward when you pull the starter handle.**
- **When operating the driving lever, keep it either fully released or fully held. Action should be prompt and continuous.**
- **When you choose to operate the lawn mower in self-propelled condition, just hold the driving lever. It can give longer life to the clutch.**

### Cutting height adjustment (Fig. 10)

By adjusting the different shifts of adjustable handlebar, the chassis height of the lawn mower can be adjusted to change the cutting height.

Fig. 10

Move the adjustable handlebar backward to adjust the cutting height higher;

Move the adjustable handlebar forward to adjust the cutting height lower;

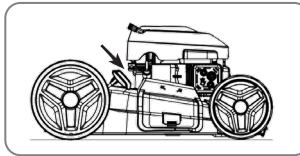

Decrease the cutting height

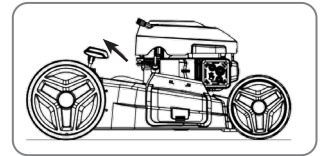

Increase the cutting height

## STARTING

### Starting the engine (Fig. 11, Fig. 12)

1. Release the driving lever(optional). If the driving lever is held during engine start, the lawn mower will move forward.
2. Press the oil pump to let fuel go into carburetor. Stand at the operating position behind the handle of the lawn mower, hold the brake lever with the handlebar.
3. Pull the starting rope slightly, when feeling the resistance force, pull promptly the rope according to the starting direction in the picture. Set back the starting rope slowly and put the starting knob on the hoop.

Fig. 11

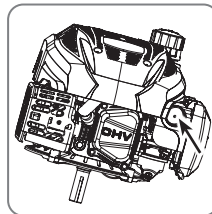
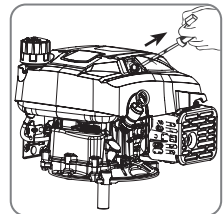

Fig. 12



pull the starting rope slowly and put the starting knob on the hoop.

**ATTENTION – DANGER!**

- Keep hands and feet away from the chassis when starting the engine and during operation.
- Continuous holding the brake lever and handlebar (keep the brake lever holding), in case of engine stop.
- The blade will rotate when start the engine.
- It is easier to start the engine on a surface without grass or with low grass, since the blade can rotate freely.

## STOP THE ENGINE

### Emergency stop

Release driving lever and brake lever.

### Normal engine stop

1. Release the driving lever.
2. Release the brake lever.

## SAFE MOWING PRACTICES

For your safety, keep all four wheels on the ground and be careful to avoid losing your footing and your control of the mower. Keep a firm grip on the handlebar, and walk, never run, with the mower. Be very careful when mowing uneven ground.

**WARNING!**

- The blade is sharp and spins at high speed.
- A spinning blade can cut you severely and can amputate fingers and toes. Wear protective footwear.
- Keep your hands and feet away from the deck while the engine is running.
- Stop the engine before performing any adjustment, inspection, or maintenance.

## Slopes (Fig. 13)

Mow across slopes, not up and down. Avoid steep slopes (more than 10°), and be careful when changing direction.

Mowing on a slope when the grass is damp or wet could cause you to slip, fall, and lose control of the mower.

## Obstacles

Use the side of the mower to cut close to large obstacles, such as fences or walls.

Push the mower around obstacles for better directional control. Be careful when mowing over obstacles embedded in the lawn, such as sprinkler heads, paving, edging, etc. Avoid anything that sticks up above the surface of the lawn.

If the blade hits something, or if the mower starts to vibrate, stop the engine immediately, disconnect the spark plug cap, and check for damage. Striking objects may damage the blade, bend the crankshaft, and/or break the deck or other components. Vibration usually indicates serious trouble.

Fig. 13

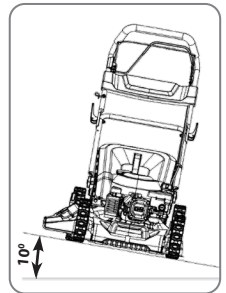
**WARNING!**

- A worn, cranked, or damaged blade can break.
- Thrown objects can cause serious injury.
- Inspect the blade regularly, and do not operate the mower with a worn or damaged blade.
- The warranty does not cover parts damaged as a result of the blade hitting a foreign object.

### Gravel and loose objects

Gravel, loose stones, and landscaping material can be picked up by the mower and thrown many feet with enough force to cause serious personal injury and/or property damage. The best way to prevent potential injury from thrown objects is to release the flywheel brake lever to stop the blade before reaching areas with gravel, loose stones, or landscaping material.

### Cutting height

Consult a local nursery or lawn and garden center for cutting height recommendations and advice about specific types of grasses and growing conditions in your area.

If you look closely, you'll see that most grass has stems and leaves. If you cut off the leaves, you'll scalp the lawn.

Let the grass recover between mowing. Your mower will work better, and your lawn will look better.

If your grass gets too tall, cut it once at the highest cutting height setting, then mow again in 2 or 3 days. Don't take off more than one third of total grass height in any one mowing, or brown patches may develop.

### Gravel and loose objects (Fig. 14)

For an even lawn finish, overlap each mowing swath by approximate 5 – 10cm. If the grass is very tall or thick, use more overlap and a narrower mowing swath.

Fig. 14

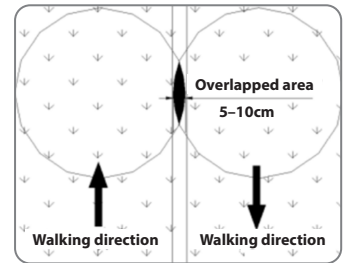

### Blade speed

The blade must spin very fast to cut properly. If engine speed drops, it could mean the engine is being overloaded by the blade trying to cut too much grass. Mow a narrower swath, move the mower slower, or raise the cutting height.

### Blade sharpness

A sharp blade cuts cleanly. A dull blade tears the grass, leaving shredded ends that turn brown. When your blade doesn't cut cleanly anymore, have it sharpened or replaced.

### Dry grass

If the ground is too dry, mowing will stir up a lot of dust. Besides being unpleasant to work in, too much dust will clog the carburetor, air filter. If dust is a problem, water your lawn the day before mowing. Mow when the grass is dry to your touch, but the soil is still moist.

### Wet grass

Wet grass is slippery and can make you lose your footing. Also, wet grass clippings will clog the deck and collect in clumps on the lawn. Always wait for wet grass to dry before mowing.

### Fallen leaves

When equipped with the grass bag, your mower can be used to pick up fallen leaves for disposal. If using the mower to bag large amount of fallen leaves, and not for mowing, set the cutting height adjustment lever at highest setting.

If you want to mulch fallen leaves into your lawn, don't let the leaf cover get too deep before you begin. For best results, start mulching while grass still shows through the leaf cover. In places where fallen leaves completely cover the grass remove the leaves by raking, or install a grass bag, so your mower can pick them up for disposal.

### Clogged deck

Before clearing a clogged deck, stop the engine and turn the fuel valve to the OFF position (if applicable). With the spark plug cap disconnected, lift the front part of the lawn mower vertically upward or tilt the mower so the carburetor side is up. Clear a clogged deck with a stick, not by your hands.



**WARNING!**



- **To prevent accidental starting, the spark plug cap should be removed before maintenance.**
- **Carry out maintenance work in accordance with the inspection chapters in this instruction manual and the requirements in the maintenance schedule.**

In order for you to take good care of your lawn mower, pay attention to the following contents, including maintenance schedule, daily inspection procedures, and simple maintenance items that can be performed with conventional hand tools.

When maintenance is difficult or special tools are needed, professional maintenance personnel/technicians or service shops will do it. The maintenance schedule is suitable for normal working conditions. If the lawn mower performs abnormal work, such as overload, please consult the dealer.



**NOTE**



**It is impossible to list all the potential hazards during maintenance in the instruction manual. Whether you are competent for maintenance work is up to your own discretion.**

### Safety warning:

Make sure that the engine is turned off before starting maintenance or repairs. This measure can eliminate serious potential hazards:

- The carbon monoxide emitted by the engine is toxic (make sure to ventilate well before operation).
- Hot parts can cause burns (the engine and exhaust system can only be touched after cooling down).
- Moving parts may cause bumps (unless instructed, it is forbidden to start the engine).
- Before starting work, please read this instruction manual to make sure you have the required technical capabilities and corresponding tools.
- Be careful when there is gasoline near the work area to reduce the possibility of fire or explosion. Use flame-retardant solvents to clean parts. Keep parts contaminated with oil away from lit cigarettes, sparks, open flames, etc.



**WARNING!**



- **The authorized service shop is more familiar with your lawn mower and has complete sets of equipment for maintenance and repair of lawn mowers.**
- **To ensure the best quality, safety and reliability, please use genuine parts from the factory. Using inferior substitutes will damage the lawn mower and will not be covered by the warranty.**

## TECHNICAL MAINTENANCE WORKS

Unit	Action	Before starting work	First 5 Hours of operation	Every 8 hours of operation or daily	First month or 10 operating hours	Every 25 Hours of operation or annually	Every 6 months or 50 operating hours	Every year or 100 operating hours	
Motor oil	Level check	☑		☑					
	Replacement		☑		☑	☑ <sup>*3</sup>	☑		
Air filter	Check	☑							
	Cleaning					☑			
	Replacement	Every year or if damaged							
Area around muffler and controls	Cleaning			☑					
Muffler and spark arrester (if installed)	Check						☑		
Air cooling system	Cleaning							☑	
Flywheel brake pad	Check-adjust						☑ <sup>*2</sup>		
Spark plug	Check-adjust						☑		
	Replacement							☑	
Valve clearance	Check-adjust							☑ <sup>*2</sup>	
Combustion chamber	Cleaning							☑ <sup>*2</sup>	
Fuel tank	Level check	☑							
	Cleaning							☑ <sup>*2</sup>	
Fuel tube	Check	Every 2 years (Replace if necessary) (x2)							
Blade bolt tightness	Check	☑							
Grass bag Check-clean G G 21 (applicable type)	Check/Cleaning	☑							
Throttle cable	Check-adjust							☑ <sup>*2</sup>	
Gear/Walking gear	Lubrication grease							☑ <sup>*2</sup>	

### Note:

- (\*1) Service more frequently when used in dusty areas.
- (\*2) These items should be serviced by your servicing dealer, unless you have the proper tools and are mechanically proficient. Refer to the shop manual for service procedures.
- (\*3) Change engine oil every 25 hours when used heavy load or in high ambient temperature.
- (\*4) For commercial use, log hours of operation to determine proper maintenance intervals.

RECOMMENDED OILS

9



NOTE



Running the engine with a low oil level can cause engine damage.

Oil is a major factor affecting performance and service life. We recommend the use of certified oils for 4-takt engines for best performance. Other high-quality detergent oils are acceptable if classified for service SF, SG, SH, SJ or higher. Do not use special additives. Motor oils with other viscosity levels, may be used only if the average air temperature in your region does not exceed the limits of the temperature range, specified in the table.

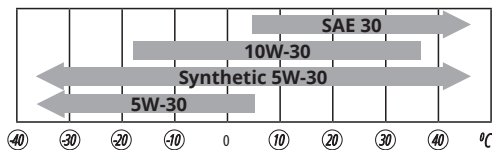

\* (4 °C) the use of SAE 30 will result in hard starting.

\*\* (27 °C) the use of 10W-30 may cause increased oil consumption. Check oil level more frequently.

Upon oil level decrease it is necessary to add the required quantity in order to provide the correct generator operation. It is necessary to check the oil levels according to technical maintenance schedule.

### ENGINE OIL CHANGE:

Drain the used oil while the engine is warm. Warm oil drains quickly and completely.

1. Wipe the oil filler area clean, then remove the oil filler cap/dipstick.
2. Place a suitable container next to the mower to catch the used oil, then tilt the mower on its right side. The used oil will drain through the filler neck. Allow the oil to drain completely. Oil suction devices may also be used.



NOTE



**Please dispose the used motor oil and the containers in a manner that is compatible with the environment. We suggest you take it in a sealed container to your local recycling center or service station for reclamation. Do not throw it in the trash, pour it on the ground or down a drain.**

3. Add the engine oil accordingly avoid spilling out.



NOTE



**Using nondetergent oil can shorten the engine's service life, and using 2-stroke oil can damage the engine.**

4. After changing the engine oil, and before starting the engine, check the oil level with the mower on a level surface:

- a). Wipe the dipstick clean.
- b). Insert and remove the dipstick without screwing it into the filler neck. Check the oil level shown on the dipstick.
- c). If the oil level is low, add oil to reach the upper limit mark on the dip stick. Do not overfill. If the engine is overfilled, the excess oil may get transferred to the air cleaner housing and air cleaner.
- d). Screw in the oil filler cap/dipstick securely.

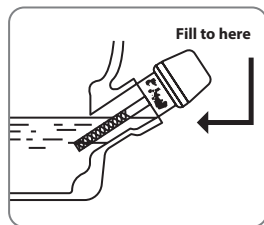
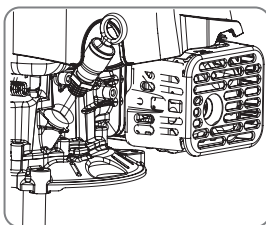

### AIR FILTER TECHNICAL MAINTENANCE

10



WARNING!



**Do not use compressed air or solvents. Pressurized air can damage the filter, and solvents can dissolve it.**

Dirty air cleaner will restrict air flow to the carburetor, reducing engine performance. If you operate the mower in very dusty areas, clean the air cleaner more often than specified in the maintenance schedule.

1. Unscrew and remove the air cleaner nuts (if applicable), then remove the air cleaner cover.
2. Remove the filter elements from the air cleaner housing, and remove the foam filter element from the paper filter element.
3. Inspect the filter elements for holes or tears; and replace them if damaged.
4. Clean the filter elements.

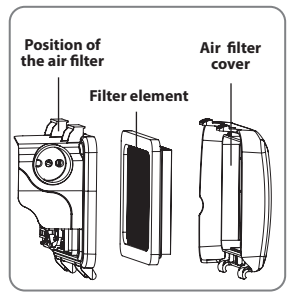

NOTE



**If the engine is running without an air filter element or the filter element is damaged, dust will enter the engine, thereby accelerating wear. Damage caused by such reasons is not covered under warranty.**

### Foam filter:

Wash with soap and warm water, rinse and dry, or wash with a non-flammable solvent and let it dry. Let the filter soak the clean oil, and then squeeze out the excess oil. If there is too much oil remaining on the foam, Gasoline engines will emit smoke during the initial start-up phase.

1. Wipe off the dirt in the air cleaner housing and cover with a damp cloth. Be careful not to let dirt get into the gas pipe of the carburetor.
2. Reinstall the air filter and the air filter cover, and press the air filter buckle to lock it.

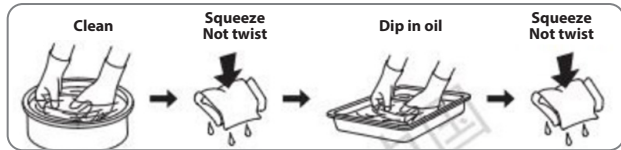

### Paper pleated filter:

To remove dirt, gently tap the filter against a hard surface. If the filter is heavily soiled, replace it with a new one.

## CHECK THE ACTION OF THE BRAKE LEVER

11

Start the engine outdoors, loosen the brake lever, and the engine quickly stops running. Otherwise, the lawn mower needs to be sent to the dealer or a service workshop for inspection and repair.

## SPARK PLUGS TECHNICAL MAINTENANCE

12

Spark plug has to be intact, without soot deposits and to have a correct gap.

1. Disconnect the spark plug cap and remove dirt from the area.
2. Use a spark plug wrench to remove the spark plug
3. Inspect the plug; replace it if the electrode is worn, or if the insulator is cracked or chipped. Recommended replacement spark plugs – F5RTC. Clean plug completely if you are going to reuse it.
4. Measure the spark plug gap with a suitable gauge. The gap should be 0.7 - 0.8 mm. Correct the gap, if necessary, by bending the side electrode.
5. Install the spark plug carefully by hand, to avoid cross-threading.
6. After the spark plug seats, tighten with a spark plug wrench to compress the washer.
7. Install the spark plug cap on the spark plug.

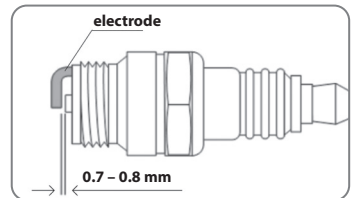



NOTE



- An incorrect spark plug can cause engine damage.
- For good performance, the spark plug must be properly gapped and free of deposits.
- When reinstalling the old spark plug, screw 1/8 to 1/4 turn after the spark plug is in place. When installing a new spark plug, you need to twist 1/2 turn.
- If the spark plug is not tightened, the engine will overheat and damage the engine. Overtightening will damage the thread of the spark plug hole.

## CARBURETOR MODIFICATION FOR ALTITUDE OPERATION

13

At high altitude, the standard air-fuel mixture will be too rich. Performance will decrease, and fuel consumption will increase. A very rich mixture will also foul the spark plug and cause hard starting. High altitude performance can be improved by specific modifications to the carburetor. If you always operate your lawn mower at altitude above 1,500 meters, have your servicing dealer perform these carburetor modifications. Even with carburetor modification, engine horsepower will decrease about 3.5% for each 300 meters increase in altitude. The effect of altitude on horsepower will be greater than this if no carburetor modification is made.



NOTE



**When the carburetor has been modified for high altitude operation, the air-fuel mixture will be too lean for low altitude use. Operation at altitude below 1,500 meters with a modified carburetor may cause the engine to overheat and result in serious engine damage. For use at low altitude, have your servicing dealer return the carburetor to original factory specifications.**

## BLADE REMOVAL AND INSTALLATION

14

Use torque wrench for blade installation. Wear gloves to protect your hands. In order to avoid tool imbalance or poor cutting effect caused by poor blade, the blade should be sharpened by a professional at the dealer. Please replace it with an original blade.

### DISASSEMBLY:

1. Turn off the fuel switch and remove the spark plug cap.
2. Lift the front part of the lawn mower vertically upward, or tilt the lawn mower so that the carburetor side is facing upward.
3. Fix the cutter head, and remove the blade bolt, dish washer, blade, and cutter seat.



NOTE



**Before disassembly, fix the blade by hand to keep it from rotating during the disassembly process.**

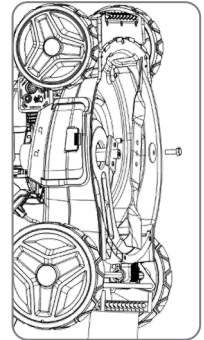

### INSTALL:

1. Clean the dust and grass clippings from the blade and the chassis.
2. The blade bolts pass through the dish washer, the blade, and the knife seat respectively, and then are fixed to the power shaft.
3. Fix the blade by hand and tighten the blade nut with a torque wrench to prevent the cutter head from rotating during the tightening process. Bolt tightening torque: 40N•m.



NOTE



The blade bolts are specially used for lawn mowers. If they need to be replaced, only original parts can be used. Otherwise, the blade may fall out of the lawn mower, causing serious personal injury.

4. After installing the blade, the blade rotates one circle to check for interference.



ATTENTION – DANGER!



The bent and deformed blade may cause serious personal injury.

If you do not have a torque wrench, please go to the service shop to tighten the blade fastening bolts.

## GRASS BAG CLEANING AND REPLACEMENT

15

**Cleaning:** Wash the bag with a garden hose, and allow it to dry completely before use; a wet bag will clog quickly.

**Replacement:** Replace a worn or damaged bag with an original genuine bag or its equivalent.

**Removal:** Unclip the plastic edges of the bag from the frame. Remove the bag from the frame.

**Big installation:** Insert the frame into the new bag. Clip the plastic edges to the frame.

## TRANSPORTING/STORAGE

16

### TRANSPORTING

#### Before loading

1. Stop the engine (if the engine has just been running, it should be cooled for at least 15 minutes before loading into the vehicle).



ATTENTION – DANGER!



A hot engine and exhaust system can burn you and can ignite some materials!

2. Take off the spark plug cap.
3. If equipped, remove the grass bag.

#### Loading and unloading

- If a suitable loading ramp is not available, two people should lift the mower on and off the transport vehicle while holding the mower level.
- Position the mower so all four wheels are on the bed of the transport vehicle. Tie the mower down with rope or straps, and block the wheels. Keep the tie-down rope or straps away from the controls, adjustment levers, cables, and the carburetor.
- The handlebar can be folded so the mower will take up less space.

### STORAGE

#### Storage preparation

Proper storage preparation is essential for keeping your lawn mower trouble-free and looking good. The following steps will help to keep rust and corrosion from impairing your lawn mower's function and appearance, and will make the engine easier to start when you use the lawn mower again.

#### CLEANING

Wash the lawn mower, including the underside of the deck.

Wash the engine by hand, and be careful to prevent water from entering the air cleaner and/or muffler.



NOTE



- **Using a garden hose or pressure washing equipment can force water into the air cleaner. Water in the air cleaner will soak the filters and can enter the carburetor or engine, causing damage.**
- **Water on a hot engine can cause damage. If the engine has been running, allow it to cool for at least 30 minutes before washing.**

**Deck:**

If using a garden hose or pressure washing equipment to clean the deck, be careful to avoid getting water into controls and cables, or anywhere near the engine air cleaner or muffler opening.

**Flush with hose connector:**

Connect the hose onto cleaning nozzle and turn on the water switch to wash the chassis. Start the engine and let the blades run at normal working speed for a few minutes (wash it on the grass or other suitable places). Do not allow water or washed debris to enter a clean water source.

**Manual cleaning:**

If there are still debris after washing, use a plastic brush or cloth to clean it.



WARNING!



1. **Ensure the throttle switch is off before removing the spark plug cap.**
2. **Wear thick gloves to avoid fingers being cut by blades.**
3. **Lift the front part of the lawn mower vertically upward, or tilt the lawn mower so that the carburetor side is facing upward.**
4. **Use a plastic brush or cloth to clean the chassis.**

**After cleaning:**

1. After cleaning, remove the hose and dry the surface of the lawn mower.
2. Place the lawn mower horizontally outdoors and start the engine until it reaches normal working temperature to evaporate residual moisture.
3. Turn off the engine and allow it to cool down.
4. After cleaning the lawn mower, let it dry. If necessary, repair the paint surface and apply a thin layer of anti-rust oil to any place that may rust. Coat the control cables with grease.

**FUEL**

Gasoline will oxidize and deteriorate in storage. Old gasoline will cause hard starting, and it leaves gum deposits that clog the fuel system. If the gasoline in your mower deteriorates during storage, you may need to have the carburetor and other fuel system components serviced or replaced.

The length of time that gasoline can be left in your fuel tank and carburetor without causing functional problems will vary with such factors as gasoline blend, your storage temperatures, and whether the fuel tank is partially or completely filled. The air in a partially filled fuel tank promotes fuel deterioration. Very warm storage temperatures accelerate fuel deterioration. Fuel deterioration problems may occur within 30 days, or even less if the gasoline was not fresh when you filled the fuel tank.

The warranty does not cover fuel system damage or engine performance problems resulting from neglected storage preparation.

You can avoid fuel deterioration problems by draining the fuel tank and carburetor, or by running the engine until it stops on its own.

**Note:**

Gasoline spoils very quickly depending on factors such as light exposure temperature and time. In worst cases, gasoline can be contaminated within 30 days.

Using contaminated gasoline can seriously damage the engine (carburetor clogged, valve stuck). Such damage due to spoiled fuel is disallowed from coverage by the warranty. To avoid this please strictly follow these recommendations:

- **Use only unleaded gasoline with an octane rating of 90–95 containing no more than 10% ethanol.**

- Use fresh and clean gasoline.
- Keep gasoline in a certified fuel container.
- If long storage (more than 30 days) is foreseen, drain fuel tank and carburetor.

### DRAINING THE FUEL TANK AND CARBURETOR

1. Drain the fuel in the fuel tank into a suitable container (it is recommended to use a commercial manual fuel pump instead of an electric pump).
2. Place the fuel switch in the "ON" position, and loosen the carburetor drain bolt counterclockwise by 1-2 turns.
3. After the fuel is drained, tighten the carburetor drain bolt



ATTENTION – DANGER!



- **Gasoline is highly flammable and explosive. You can be burned or seriously injured when handling fuel.**
- **Stop the engine and allow it to cool before handling fuel.**
- **Keep heat, sparks, and flame away.**
- **Handle fuel only outdoors.**
- **Wipe up spills immediately.**

### ENGINE OIL

Change the engine oil.

### ENGINE CYLINDER

1. Remove the spark plug.
2. Pour of clean engine oil into the cylinder.
3. Pull the starter grip several times to distribute the oil in the cylinder. Reinstall the spark plug.
4. Pull the starter grip slowly until resistance is felt, then return the starter grip gently. This closes the valves so moisture cannot enter.

### HANDLEBAR FOLDING

1. Remove the grass bag, side discharge outlet, mulching plug (if installed).
2. Loosen or remove the two locking knob at the lower handbar seats, then fold the lower handbar (if installed).
3. Pull the handlebar struts to release them from the locating grooves, then swing the handlebar forward with the flywheel brake lever and drive clutch lever held by your hand. Don't allow the cables to be bent or pinched.

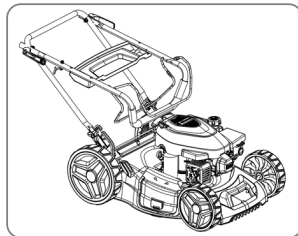

Fig. 15

### PREPARATION FOR OPERATION AFTER STORAGE

- If your mower will be stored with gasoline in the fuel tank and carburetor, it is important to reduce the hazard of gasoline vapor ignition. Select a well-ventilated storage area away from any appliance that operates with a flame, such as a furnace, water heater, or clothes dryer. Also avoid any area with a spark-producing electric motor, or where power tools are operated.
- If possible, avoid storage areas with high humidity, because that promotes rust and corrosion.
- Unless all fuel has been drained from the fuel tank (if applicable), turn the fuel valve to the OFF position to reduce the possibility of fuel leakage.
- Place the mower with its wheels on a level surface. Tilting can cause fuel or oil leakage.
- The handlebar can be folded for compact storage.
- With the engine and exhaust system cool, cover the mower to keep out dust. A hot engine and exhaust system can ignite or melt some materials.
- Do not use plastic sheet as a dust cover. A nonporous cover will trap moisture around the mower, promoting rust and corrosion.
- Keep the minors out of reach.

## STORAGE INSTALLATION

1. Hold the brake lever and the drive lever, and raise the handlebar according to the reverse steps of disassembly. Be careful not to bend the cable.
2. Install grass bag, side discharge, and mulching plug (if necessary).

## USAGE AFTER STORAGE

- Check the lawn mower according to the contents of the “Pre-operation inspection” in this manual.
- The fuel has been exhausted during storage preparation, and fresh gasoline must be added to the fuel tank. Before refueling, make sure that the gasoline in the container is fresh. If the gasoline is stored for a long time, it will oxidize or deteriorate, making it difficult to start the engine.
- During storage preparation, if engine oil has been added to the cylinder, the engine will emit smoke for a short period of time during the starting phase. This is a normal phenomenon.

## TROUBLESHOOTING

17

Problem	Possible cause	Remedy
<b>Machine does not start</b>	Fuel valve OFF (if applicable).	Turn fuel valve ON (if applicable).
	Out of fuel.	Refuel.
	Bad fuel; mower store without treating or draining gasoline, or refueled with bad gasoline.	Drain fuel tank and carburetor. Refuel with fresh gasoline
	Spark plug faulty, fouled, or improperly gapped. Spark plug wet with fuel (flooded engine).	Clean, adjust or replace spark plug. Dry and reinstall spark plug. Start engine with throttle lever in HIGH position.
	Fuel filter clogged, carburetor malfunction, ignition malfunction, valves stuck, etc.	Take the lawn mower to the dealer for repair or refer to the maintenance manual.
<b>Lack of power</b>	Not placed in “high” gear. (When equipped with a throttle switch).	Shift to “high” gear.
	The grass is too deep.	Increase the cutting height, narrow the cutting width, or increase the number of cuts.
	Blockage in the chassis.	Clean the chassis.
	The filter element is clogged.	Clean or replace the filter element.
	Bad fuel: improperly handled or not drained fuel during storage: bad fueladded.	Drain the fuel in the tank and carburetor and add new fuel.
<b>Excessive vibration</b>	Clogged fuel filter, carburetor failure, ignition coil failure, valve sticking, etc.	Replace blades (see “Turning/replacing blades”)
	The chassis is blocked by grass or stones.	Clean the chassis.
	The blade is loose, bent, damaged, or the sharpness of the blade is unbalanced.	Tighten the blade fixing bolt: replace the damaged blade.
<b>Poor cutting quality; poor performance in grass bags</b>	Mechanical damage, such as bent crankshaft.	Take the lawn mower to a dealer for repair or refer to the repair manual.
	The lawn mower works too fast and does not meet the lawn condition.	Loosen the driving lever and push it into place.
	Improper cutting height setting.	Modify the cutting height.
	Grass bag is too full or clogged.	Empty the grass bag. Need to be cleaned if clogged.
	Chassis block.	Wash the chassis.
	The blade is blunt, worn, or damaged.	Sharpen or replace the blade if necessary.
The blade is improperly installed.	Take the lawn mower to the dealer for repair or refer to the maintenance manual.	

The international manufacturer warranty is 1 year. The warranty period starts from the date of purchase. In cases when warranty period is longer than 1 year according to local legislation please contact your local dealer. The Seller which sells the product is responsible for granting the warranty. Please contact the Seller for warranty. Within the warranty period, if the product fails because of defects in the production process, it will be exchanged on the same product or repaired.

All faults caused by the manufacturer during the warranty period will be eliminated free of charge. Warranty repair is carried out only if you have a fully completed warranty card, the Buyer's signature of acceptance of the warranty terms, as well as a document supporting the purchase (cash receipt, sales slip or invoice). In the absence thereof, as well as in the event of errors or corrections not authenticated by the seller's seal or illegible inscriptions in the warranty card or tear-off coupon, no warranty repair is carried out, no objections to quality are accepted and the warranty card is withdrawn by the service center as invalid. The device is accepted for repair clean and full.



# EC Declaration of Conformity

Nr. 262

The following products have been tested by us with the listed standards and found in compliance with the European Community Machinery Directive 2006/42/EC, Electromagnetic compatibility Directive (EMC) 2014/30/EC, Noise Directive 2000/14/EC.

Manufacturer: DIMAX INTERNATIONAL GmbH  
Address: Flinger Broich 203, 40235 Duesseldorf, Germany  
Product: Gasoline lawn mower "Könner & Söhnen"  
Type / Model: KS 46LMG, KS 51LMG-SP

The statement is based on a single evaluation of above mentioned products. It does not imply an assessment of the whole production and does not permit the use of the test lab. logo. The manufacturer should ensure that all product in series production are in conformity with the product sample detailed in this report. The applicant should hold the whole technical report at disposal of the competent all the right.

Applied EC Directives: 2006/42/EC Machinery Directive  
2014/30/EC Electromagnetic compatibility Directive  
2000/14/EC Noise Directive

Applied Standards: EN ISO 14982:2009  
EN ISO 5395-1:2013/A1:2018  
EN ISO 5395-2:2013/A2:2017  
ISO 11094:1991

Gasoline engine corresponds to European Emission Standard Euro V (Stage V). This is confirmed by EU TYPE-APPROVAL CERTIFICATE issued by department of transport of Madrid, Spain.  
Technical service responsible for carrying out the test - IDIADA.  
Date of issue 04/11/2024 | 22/11/2024

## 2000/14/EC\_2005/88/EC Annex VI

For model KS 46LMG Noise guaranteed  $L_{wa} = 96$  dB (A).  
For model KS 51LMG-SP Noise guaranteed  $L_{wa} = 98$  dB (A).



25

**Issued Date:** 2025-12-11  
**Place of issue:** Duesseldorf  
**Director:** Fomin P.

*P. Fomin*

**DIMAX**  
International GmbH  
Flinger Broich 203 40235 Düsseldorf  
USt-ID DE296177274  
koenner-soehnen.com

We DIMAX INTERNATIONAL GmbH hereby declare that specified above conforms covering European Parliament and Council Directives, 2006/42/EC of 17 May 2006 Machinery Directive, Electromagnetic compatibility Directive (EMC) 2014/30/EC of 26 February 2014, Noise Directive 2000/14/EC of 8 May 2000. The CE mark above can be used under the responsibility of manufacturer. After completion of an EC declaration of Conformity and compliance with all relevant EC directives.

## CONTACTS

**Deutschland:**

Hergestellt unter Lizenz und Kontrolle der DIMAX International GmbH.

Importeur und Vertreter in Deutschland:  
DIMAX International GmbH, Flinger Broich 203, 40235  
Düsseldorf, Deutschland. Produziert in VRC.

amazon@dimaxgroup.com

[www.konner-sohnen.com](http://www.konner-sohnen.com)

---

**European Union:**

Manufactured under license and control of DIMAX International GmbH, Flinger Broich 203, 40235  
Duesseldorf, Germany.

Importer and representative in Netherlands DIMAX International Poland Ltd, Południowa 8 st,  
05-830 Stara Wieś, Poland. Assembled in PRC.

amazon@dimaxgroup.com

[www.konner-sohnen.com](http://www.konner-sohnen.com)

---

**The United Kingdom:**

Innovation Trade Ltd., 63/66 Hatton Garden Fifth Floor,  
Suite 23, London, EC1N 8LE, info.uk@dimaxgroup.de

**Technical support**

support.uk@dimaxgroup.de

[www.konner-sohnen.uk](http://www.konner-sohnen.uk)

---

**France:**

Fabriqué sous licence et contrôle de DIMAX International GmbH, Flinger Broich 203, 40235  
Düsseldorf, Allemagne.

Importateur et représentant en France et en Belgique  
DIMAX International Poland Ltd, Południowa 8 st,  
05-830 Stara Wieś, Pologne. Assemblé en RPC.

innovationtrade8@gmail.com

[www.konner-sohnen.fr](http://www.konner-sohnen.fr)

---

**España:**

Fabricado bajo licencia y control de DIMAX International GmbH, Flinger Broich 203, 40235  
Düsseldorf, Alemania.

Importador y representante en España de DIMAX International Poland Ltd, Południowa 8 st,  
05-830 Stara Wieś, Polonia.

Ensamblado en la República Popular China.

amazon@dimaxgroup.com

[www.konner-sohnen.es](http://www.konner-sohnen.es)

---

**Polska:**

Wyprodukowano na licencji i pod kontrolą DIMAX International GmbH, Flinger Broich 203,  
40235 Duesseldorf, Niemcy.

Importer i przedstawiciel w Polsce:  
DIMAX International Poland Sp.z o. o. ul. Południowa 8,  
05-830 Stara Wieś, Polska. Zmontowany w CRL.

amazon@dimaxgroup.com

[www.konner-sohnen.pl](http://www.konner-sohnen.pl)

---

**Україна:**

Виготовлено за ліцензією та під контролем  
DIMAX International GmbH, Flinger Broich 203,  
40235 Дюссельдорф, Німеччина.

Імпортер та представник в Україні:  
ТОВ "ТЕХНО ТРЕЙД КС" вул. Електротехнічна 47,  
02225, м. Київ, Україна. Змонтовано в КНР

[www.konner-sohnen.com.ua](http://www.konner-sohnen.com.ua)